

Application Note

PUMP CONTROL WITH FLOATING INVERTER-DRIVEN MOTOR. SET UP EXAMPLE

This document describes a basic set up for pump control with floating inverter-driven motor, according to the connection set up shown in figure 1.

PID set up:

F02=1; Control by terminals
 E61=3; Analog input (T12) as PID set point (process command) value
 E62=5; Analog input (C1) as PID feedback value
 J01=1; PID normal operation (2= inverse operation)
 J02=1; PID set point (process command) by analog signals
 J03=0.3; P gain PID controller
 J04=0.1; I gain PID controller
 J05=0; D gains PID controller
 J15=20 Hz; Stop Frequency for slow flow rate
 J16=10 s; Stop Timer
 J17=28; Start Frequency
 E43; Value displayed in LED monitor (10 PID command, 12 PID feedback)

F07=10.00 s; Acceleration time
 F08=10.00 s; Deceleration time

Pump control set up:

J25=2; Enable floating-inverter driven pump control
 J26=1, J27=1, J28=1; Enable pumps 1-3

E01=51; Terminal X1 to enable pump 1 (Optional)
 E02=52; Terminal X2 to enable pump 2 (Optional)
 E03=53; Terminal X3 to enable pump 3 (Optional)

E20=60; Transistor output Y1 to supply pump 1 with the inverter
 E21=62; Transistor output Y2 to supply pump 2 with the inverter
 E22=64; Transistor output Y3 to supply pump 3 with the inverter

J45=61; Relay Y1A/B/C to supply pump 1 with commercial power
 J46=63; Relay Y2A/B/C to supply pump 2 with commercial power
 J47=65; Relay Y3A/B/C to supply pump 3 with commercial power

J34=49 Hz; Frequency for sequenced start of a pump
 J35=5 s; Timer for sequenced start of the pump
 J36=25 Hz; Frequency for sequenced stop of a pump
 J37=5 s; Timer for sequenced stop of a pump

J38=0.200 s; Contactor delay time

J39=5 s; Deceleration time during sequenced start
 J40=5 s; Acceleration time during sequenced stop

J32=24 h; Periodic switching Time for motor drive (Optional)

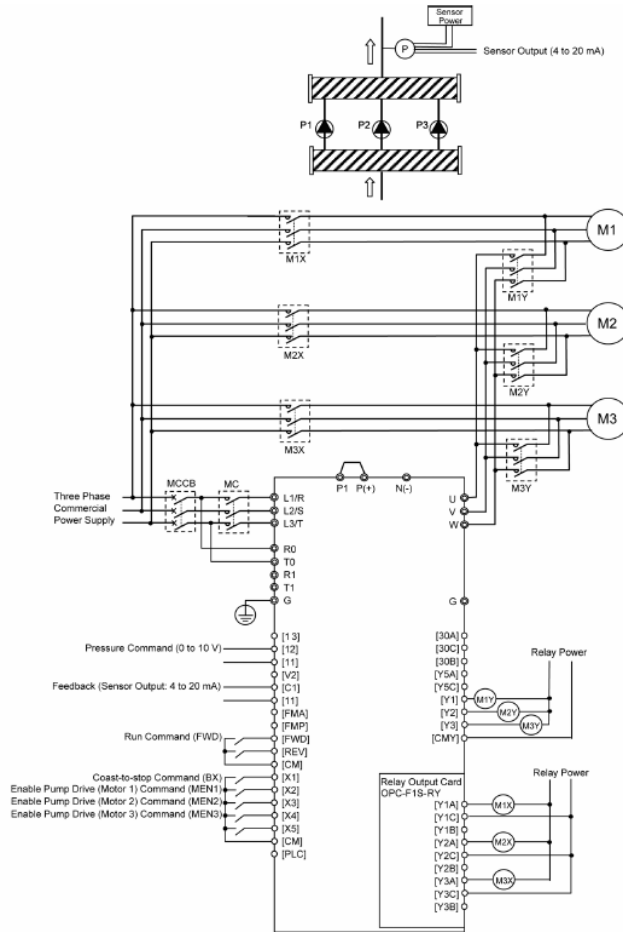

Figure 1. Connection set up with floating inverter-driven pump.