



Starting guide of FRENIC Multi (E1S) in Lift Applications



Revision date
31/08/06_1e



Index

Introduction	3
<u>Section 1</u>	
Power Terminals	4
Control Terminals	5
Connection Example	8
Keypad	9
Example of parameter configuration	10
Time Diagram (open loop)	11
<u>Section 2</u>	
Special Functions	
Brake control (BRKS)	12
Auto tuning	12
<u>Section 3</u>	
Alarms	
List of error codes and possible causes	13
<u>Section 4</u>	
Options	
Braking resistors	15



Introduction

The new FRENIC Multi inverter has some functionalities suited for lift applications: S acceleration/deceleration ramps, Fan Stop function, Brake control function...

This starting guide provides the basic information about how to install and set up FRENIC Multi E1S-4 series inverters (Three Phase 400 VAC supply).

In the case that you want to use E1S-2 series inverters (Three Phase 200 VAC supply) or E1S-7 series inverters (Single Phase 200 VAC supply), please check the differences with Fuji Electric.

For additional information about the hardware and other functions there is an INSTRUCTION MANUAL for FRENIC Multi.

Section 1 contains information about how to connect and program the inverter and a basic set up of some functions.

Section 2 contains detailed information about special functions for lift applications.

For beginners is very useful to start reading chapter about timing diagrams (Open loop applications).

The inverter can be used in Open Loop vector control (without encoder). Also can be used in Scalar control (fixed boost V/f control).

Please note that the suggested values are only tentative examples and could not work properly in your application.



SECTION 1

Power terminals

Symbol	Function	Description
L1/R, L2/S, L3/T	Mains supply terminals	3 Phase mains supply: - Supply voltage for E1S-4: 380-480 V 50/60 Hz. - Supply voltage for E1S-2: 200-240 V 50/60 Hz. or 1 Phase Mains supply: - Supply voltage for E1S-7: 200-240 V 50/60 Hz.
U, V, W	Motor (output) power terminals	Terminals to connect (supply) the motor
P(+), DB	Braking resistor connection terminals	External Braking resistor connection to the internal braking transistor (chopper). See note.
P(+), N(-)	DC bus terminals	<i>Do Not connect the braking resistor to these terminals !!!</i>
G	Protecting earth Terminal	Earth connection for motor and inverter

For more detailed information go to page 8, "Connection example".

Note: To select the correct braking resistor, go to Section 4 "Options – Braking resistors".



Control Terminals

FRENIC Multi inverter has 7 digital inputs (all 7 can be configured), 2 transistor digital outputs and 1 relay digital output (all of them can also be configured).

Control terminals description

Symbol	Type	Programmable	Example of use	Description
PLC	Digital inputs/outputs supply (+24V DC)	--	--	Power supply for the digital inputs / outputs Specifications: 24 V 50 mA.
CM	Digital inputs signal common.	--	--	Digital signals common. Isolated from terminals 11 y CMY.
FWD	Digital input	YES	--	External RUN FORWARD signal Use E98 to program desired function.
REV	Digital input	YES	--	External RUN REVERSE signal Use E99 to program desired function.
X1-X5	Digital input	YES	Speed selection Ramp selection Inverter Reset	Programmable digital inputs. Program the desired function using E01 to E05
30 A, B, C	Relay output	YES	Brake control signal Alarm output signal	Programmable relay digital output. Use E27 to program desired function.
Y1-Y2	Transistor outputs	YES	Same as relay output 30 A, B, C	Programmable transistor digital outputs. Use E20-E21 to program desired functions.
CMY	Signal Common for transistor digital outputs	--	--	Signal common for transistor digital outputs.

Electrical specifications of the digital inputs:

ON Voltage Level: 2 V
OFF Voltage Level: 22-27 V
ON current: Max. 5 mA

Electrical specifications of the digital outputs:

Relay Contact:

Max. allowed current for 250V AC: 0.3 A
Max. allowed current for 48V DC: 0.5 A

Transistors:

ON Voltage Level: 2 V
OFF Voltage Level: Max. 27 V
Max. allowed current in ON state: 50 mA.



Control terminals connection

Digital inputs can be configured as NPN (sink) or PNP (source). This can be configured using the switch SW1 located on the control board.

The factory (default) set up is NPN.
Please study the following connection examples:

a) INPUTS

Connection Example: PNP (source) input

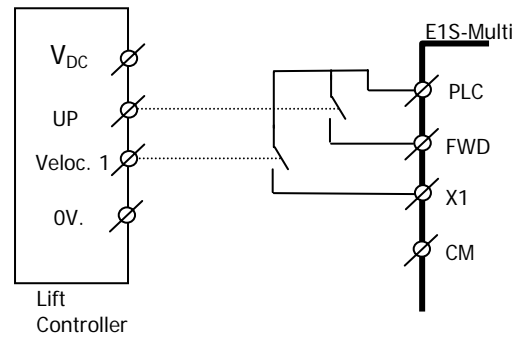
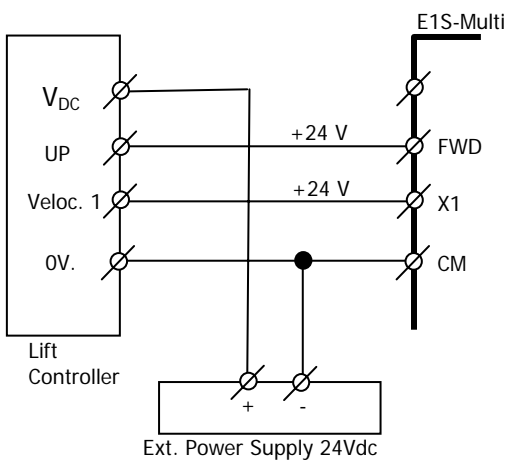

Connection Example: NPN (sink) input

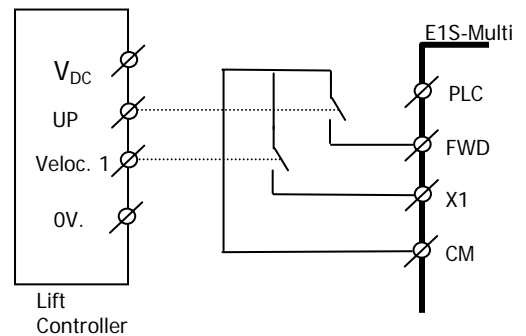
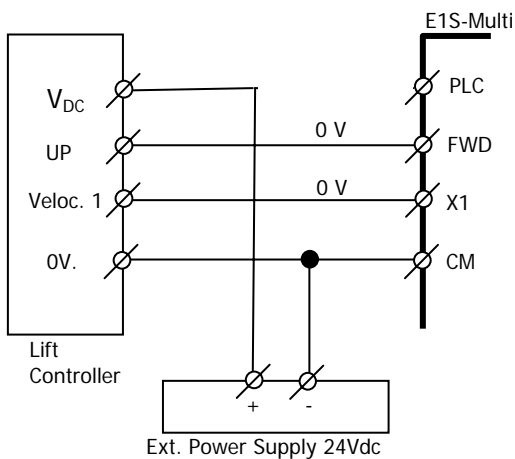



b) OUTPUTS

The logic of transistor digital outputs depends on the connection.

Connecting (-) to the transistor common CMY we will have NPN signal.
Connecting (+) to the transistor common CMY we will have PNP signal.

Please study the following connection examples:

Connection example: PNP output

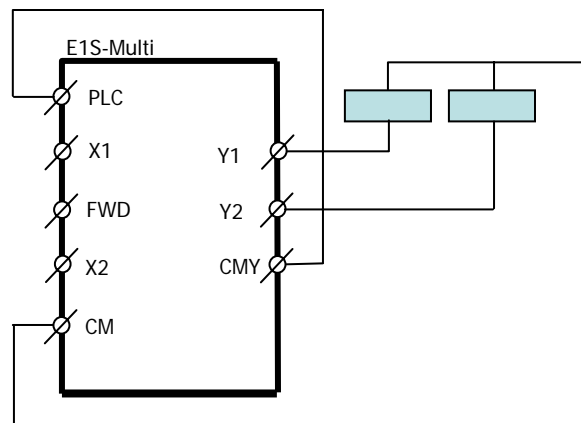
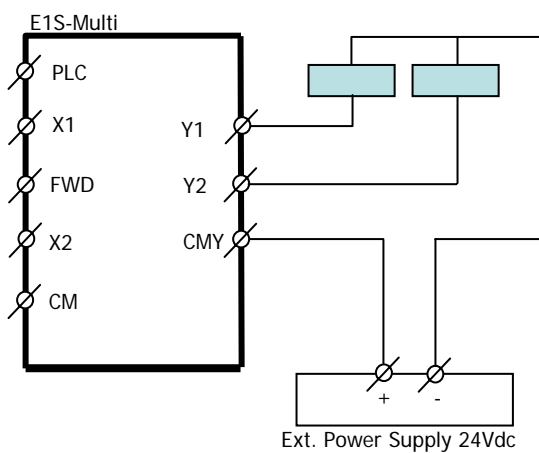

Connection example: NPN output

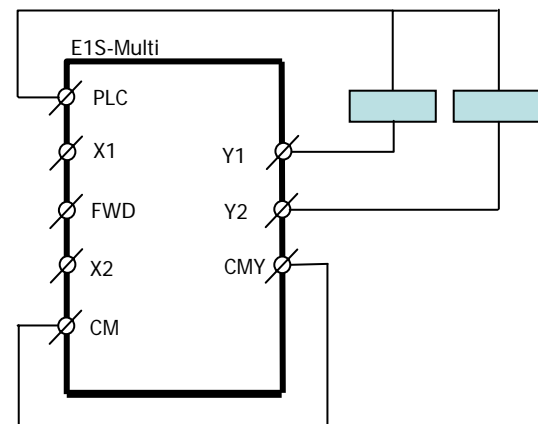
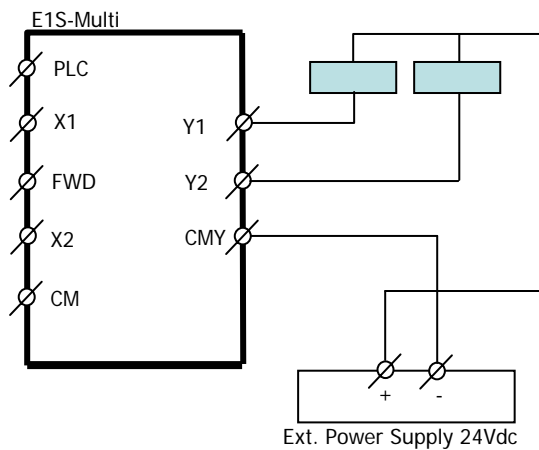

Relay Connection:

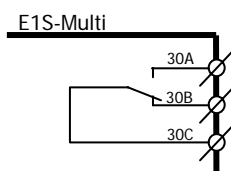



Connection example

The functions related with the following connection example are listed on page 10.

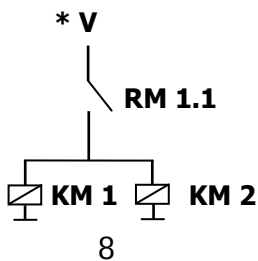
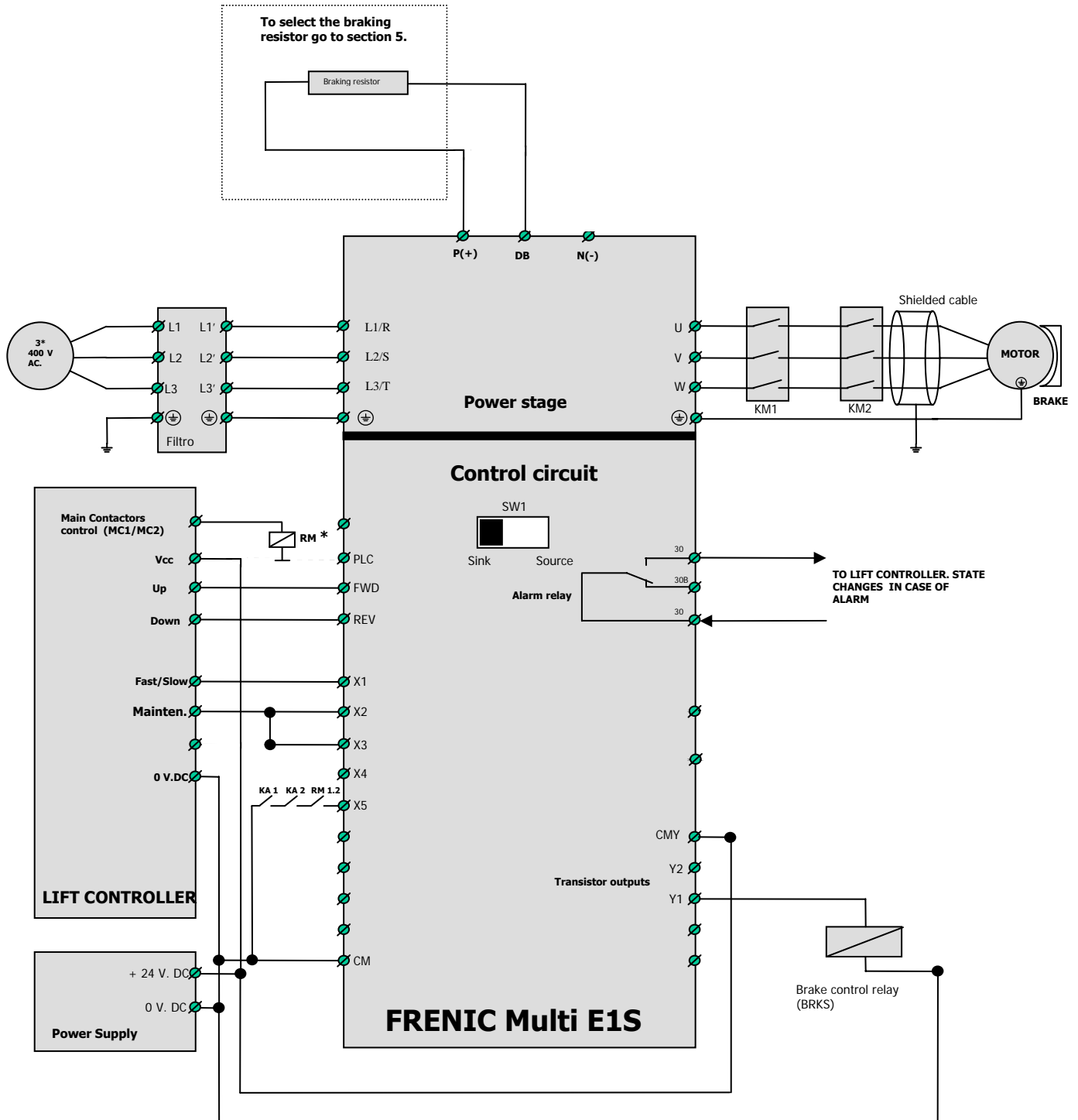

COMPONENTS TO SWITCH ON/OFF MAIN CONTACTORES AND INVERTER ENABLE SIGNAL

KM 1: Main Contactor 1
KM 2: Main Contactor 2
RM: Relay to switch ON/OFF main contactors (KM 1 y KM 2)
RM 1.1: First (NO) Contact of RM relay (switch ON/OFF main contactors)
RM 1.2: Second (NO) Contact of RM relay (FRENIC Multi E1S enable)



Keypad

The Keypad may be used to program the inverter, read the inverter status and/or run the inverter manually.

Available menus in programming mode :

- Menu 0. "Basic Functions" (Shows the basic functions to run the inverter)
- Menu 1. "Functions values change" (Shows all function groups: F, E, C, P, H,...)
- Menu 2. "Functions values check" (Shows only the functions that have been modified from factory settings)
- Menu 3. "Operation monitor" (Shows necessary information for maintenance or operation)
- Menu 4. "Input/Output check" (Shows the status of inverter digital inputs and outputs)
- Menu 5. "Maintenance" (Shows information like Inverter Run time)
- Menu 6. "Alarm Information" (Shows information about the last 4 alarm events)

To control the inverter from the keypad (local mode), do the following

Press FWD or REV key to run the motor in the forward or reverse direction and pulse STOP key to stop the motor.
 Press arrow keys to increase or reduce the speed setting.
 Press FUNC/DATA key to select the value displayed on the 7 segment LED display: Output Frequency, output current, line speed,...

Operation of the Keypad

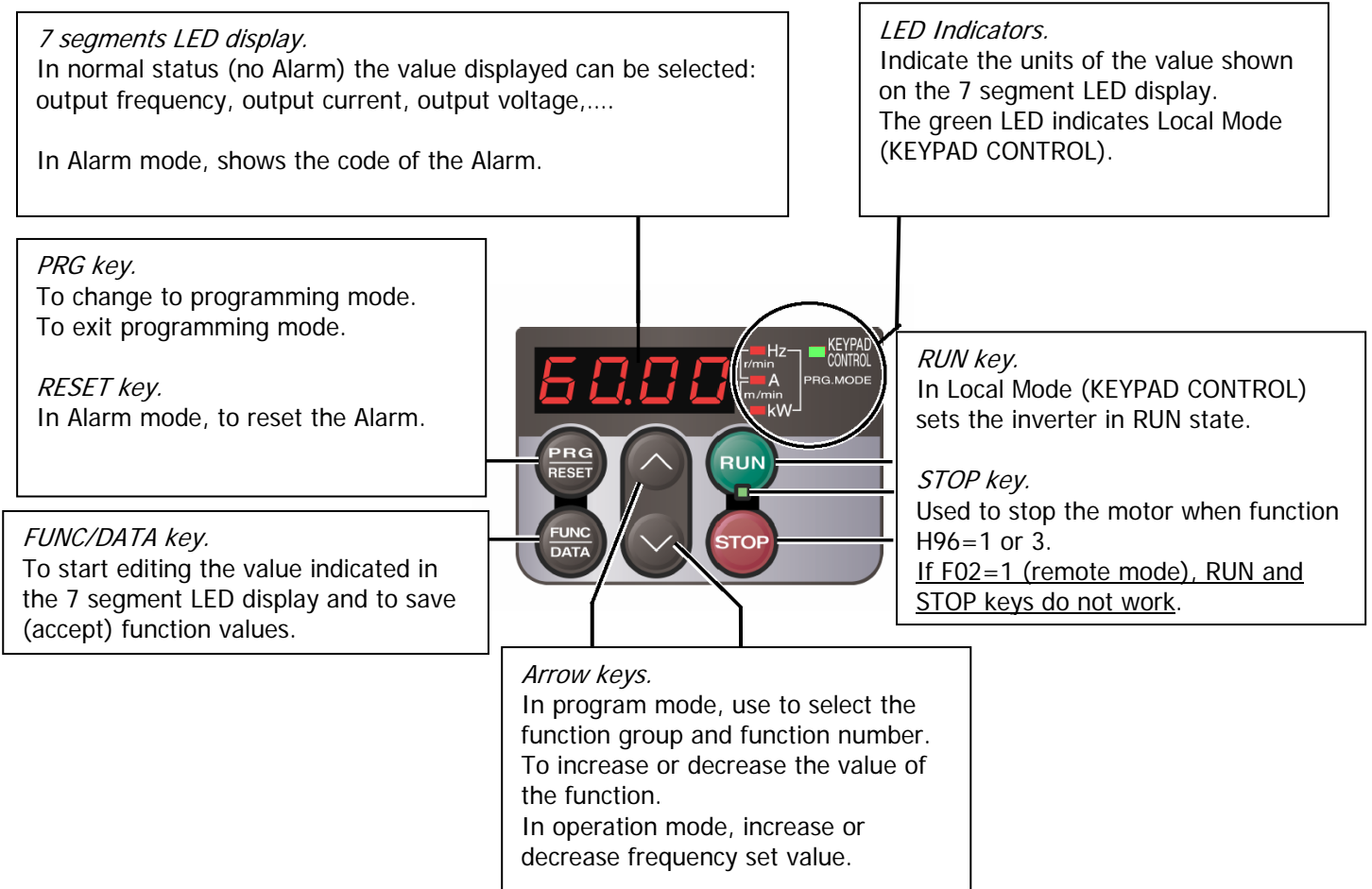



Example of inverter set up

A list of function values used in a typical lift application (according to the connection example of page 8) is shown below.

NOTES:- Consider that these function values are tentative and may not work correctly in your application.
 - First change all the rest of function values and when you finish set this function to 3.

Function	Value	Comments
F00	3*	Enable both data protection and digital frequency reference protection
F01	0	Speed selection by digital inputs and keypad
F02	1	Remote mode (FWD and REV by terminal command)
F03	50	Maximum frequency (Hz)
F04	50	Motor base (rated) frequency (Hz)
F05	400	Motor voltage at base frequency (V)
F07	2.0	Acceleration time 1 (s)
F08	1.5	Deceleration time 1 (s)
F09	0.0	Automatic torque boost.
F20	0.5	DC Braking starting frequency (Hz)
F21	80	DC Braking level (0-100 %)
F22	1.0	DC Braking time (0.1-30 s)
F23	0.5	Starting frequency (Hz)
F24	0.5	Starting frequency holding time (s)
F25	0.5	Stop Frequency (used for the brake control)
F26	10	Inverter switching frequency (kHz)
F42	1	Dynamic torque vector operation (for V/f operation set F42=0)
E01	0	Digital input X1 configured as select multi-frequency SS1
E02	1	Digital input X2 configured as select multi-frequency SS2
E03	4	Digital input X3 configured as select ACC/DEC time
E05	1007	Digital input X5 configured as inverter enable (BBX)
E10	2.0	Acceleration time 2 (s)
E11	0.01	Deceleration time 2 (s)
E20	57	Digital Output Y1 configured as brake control signal (BRKS)
C05	50.0	Multi-Frequency 1 (fast speed)
C06	25.0	Multi-Frequency 2 (maintenance speed)
P01	Motor data	Motor pole number
P02	Motor data	Motor rated capacity (kW)
P03	Motor data	Motor rated current (A)
P06	Motor data	Motor no-load current (example: 40-60% of P03 value)
P12	Motor data	Motor slip compensation (Hz)
H04	2	Number of times to perform Auto-reset
H05	5	Time interval between two consecutive Auto-reset (s)
H06	0	Cooling Fan ON/OFF control
H07	2	Strong S-curve activation
J68	10%	Brake release current. See J69, J70
J69	0.5	Brake release frequency (Hz). See J70
J70	0.5	Brake release timer (s) after frequency is greater than J69.
J71	0.5	Brake closing frequency (Hz). See J72
J72	0.5	Brake closing timer (s) after frequency is smaller than J71.



Timing diagram

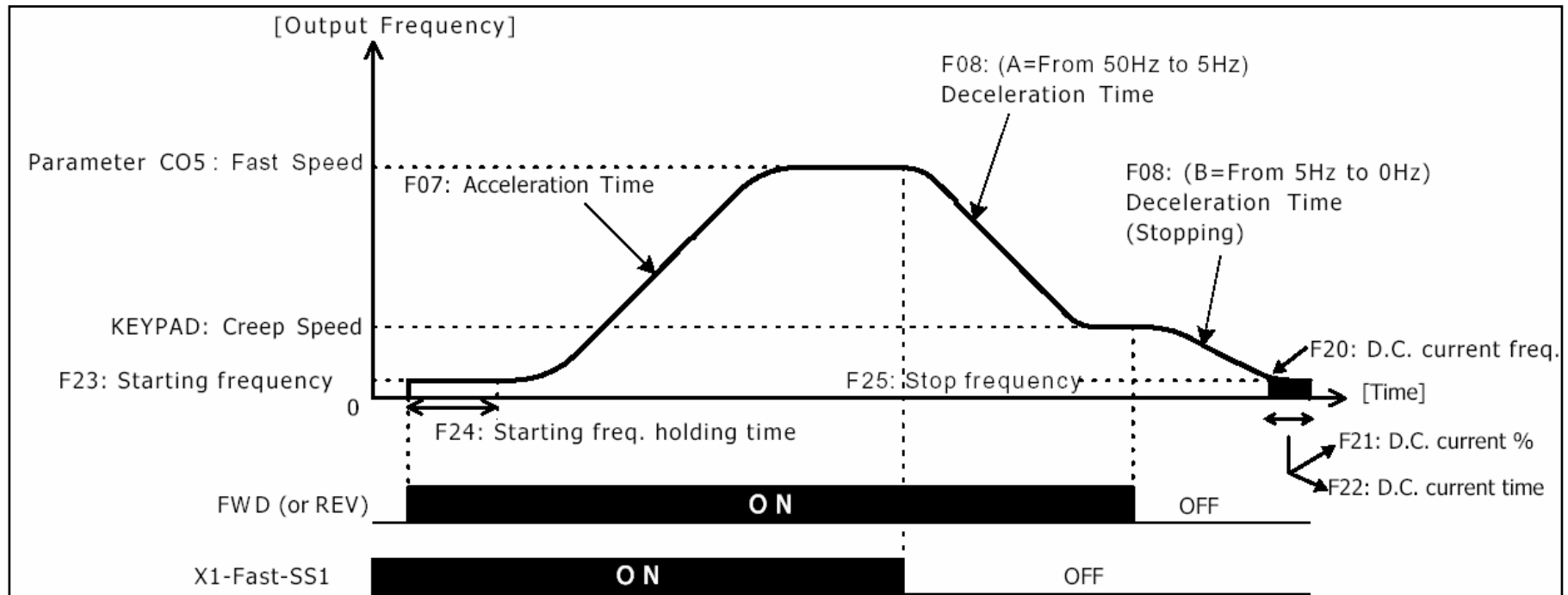

The timing diagram is based on the function values and connection set up of pages 8 and 10 respectively.

- The fast speed has been programmed in function C05 (50.0 Hz) and is activated when digital input X1 is in ON state.
- The creep speed has been programmed in keypad reference (5.0 Hz) and is activated when digital input X1 is in OFF state.
- The S curves are activated (H07=2) leading to a 10% time increase with respect to the linear acceleration (F07) and deceleration (F08) times.
- If F07=2.0 s, the total acceleration time from 0 Hz to 50 Hz is: $2.0 \times 1.2 = 2.4$ s.
- If F08=1.5 s, the total deceleration time from 50 Hz to 5 Hz and 5 Hz to 0 Hz is: $(0.9 \times 1.5) \times 1.2 + (0.1 \times 1.5) \times 1.2 = 1.8$ s.



SECTION 2

SPECIAL FUNCTIONS

Brake control (BRKS)

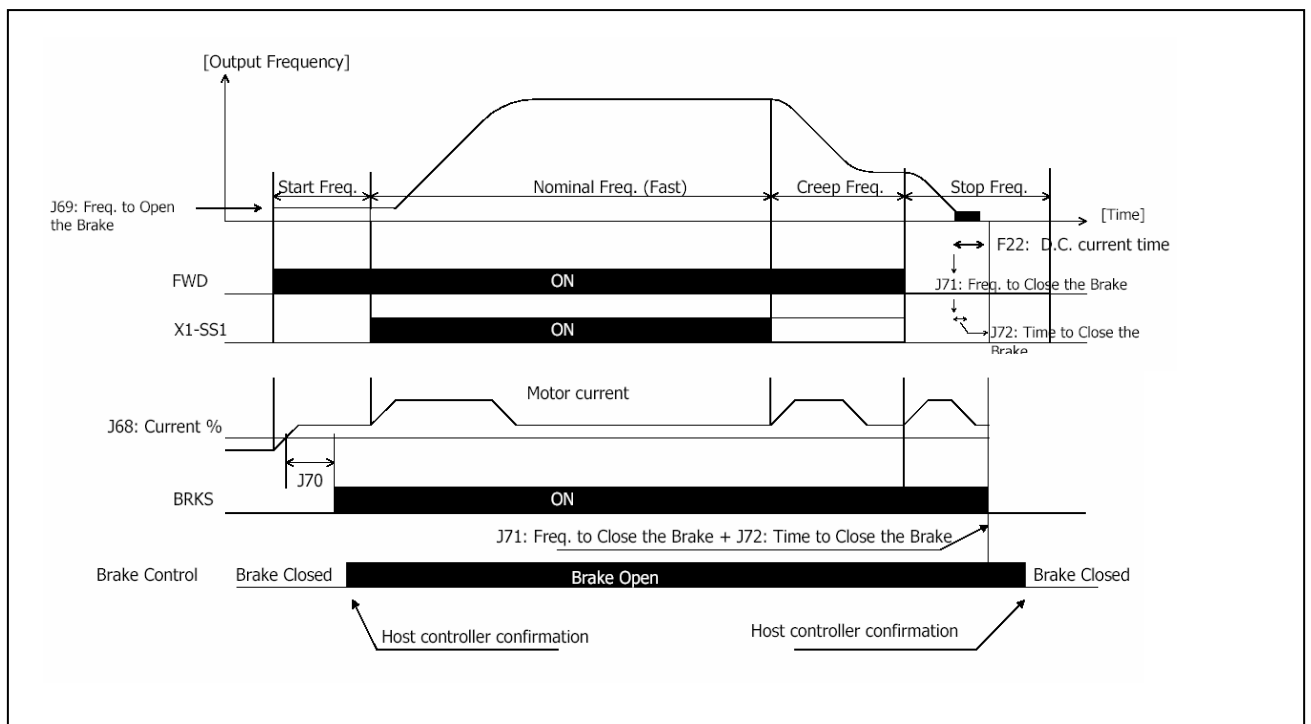

Static Auto-tuning

Setup the function values like the following example according to your motor data:

P01=4 (Motor Pole number), **P02=4 kW** (Motor capacity), **P03=9 A** (Motor rated current), **P06=5 A** (Motor No-load current), **P12=1 Hz.** (Motor slip frequency) y **P99=4** (Motor type).

Set the function P04 to 1 and give RUN command to the inverter (RUN key in LOCAL mode or FWD input in REMOTE mode).

NOT: Check the connection between Motor and Inverter (for example main Contactors at the inverter output) in case that Auto-tuning can not be performed correctly.



SECTION 3

List of alarm codes and possible causes

Alarm	Alarm code	Alarm description	Possible causes
Over current protection OC n n = 1 (Acceleration) n = 2 (Deceleration) n = 3 (At constant speed)	OC	Instantaneous over current during acceleration, deceleration or at constant speed. NOTE: Is caused due to a high current peak during very short time.	Small ramp times. Brake not open. Short circuit at the output between phases or earth. Check output and motor connection terminals. Check safety circuit. Check door locks.
Over voltage OU n n = 1 (Acceleration) n = 2 (Deceleration) n = 3 (At constant speed)	OU	Over voltage in the DC link during acceleration, deceleration or at constant speed.	Braking resistor not connected or damaged. Counterweight not properly dimensioned. Deceleration time too short. Fasten connection terminals. Verify mains supply.
Under voltage	LU	Voltage drop in the DC link	Voltage supply too low. Failure in the mains supply. Acceleration too fast. Excessive load. Verify that input terminals are properly fastened.
Input phase loss	Lin	One mains phase is not connected to the inverter supply input	Burned fuse in the mains supply. Input terminals are not properly fastened.
Output phase loss	OPL	One motor phase is not connected to the inverter output	Verify motor connection. Verify that terminals are properly fastened. Verify motor status (phase to phase resistance, motor isolation).
Overheating	OH1	The inverter heat sink is too hot.	Inverter fan is damaged. The ambient temperature is too high.
External alarm	OH2	External alarm (THR)	Digital input programmed with value 9 (THR) is not active.
Over temperature in the motor (PTC)	OH4	The motor temperature is too high. PTC protection has gone off. See function H26.	The motor is too hot. The ambient temperature is too high.



Alarm	Alarm code	Alarm description	Possible causes
Electronic thermal	OL1	Overload motor 1 (<u>Defined by the user</u>)	The inverter has reached 100% of the overload level (i ² t) defined by the user (functions F10 to F12). Check motor size, motor correct operation.
Overload protection	OLU	Inverter overload	Excessive temperature in IGBT. Verify ventilation. Verify F09 (one value too high can cause this failure). Verify the load.
Memory error	Er1	Memory error	Data loss or data incorrect.
Keypad communication error	Er2	Error in keypad communications	The keypad has been disconnected meanwhile the inverter is in RUN state (local mode). See F02. Communications circuit of the keypad damaged.
CPU Error	Er3	CPU error	CPU damaged.
Option communication error	Er4	Communications error in option card	The option has not been installed correctly. Verify installation and connection.
	Er5	Error in option card	Verify set up in option card (switch and jumpers)
Operation error	Er6	The digital input programmed as <i>force to stop</i> is active (<u>Defined by the user</u>)	The digital input programmed with value 30 is active. Verify H96.
Tuning error	Er7	Error during Auto Tuning procedure	The connection between motor and inverter has been interrupted during Auto Tuning procedure. Verify main contactors between motor and inverter.
RS485 communications error	Er8 / ErP	RS485 communications error or in the RS485 option card	Error in RS485 communications. Caused by noise or wire break.



SECTION 4

Options Braking resistors

For the correct values of the external braking resistor please refer to the following tables:

[400V]

Inverter	Braking resistor	Duty Cycle	Minimum resistance value [Ω]
FRN3,7E1S-4A	RES PR 130 OHM/600 W	Standard	130
FRN5,5E1S-4A	RES PR 80 OHM/600 W	Standard	80
FRN7,E1S-4A	RES PR 80 OHM/600 W	Standard	60
	RES PR 60 OHM/1000 W	High	60
FRN11E1S-4A	RES PR 40 OHM/1500 W	Standard	35
FRN15E1S-4A	RES PR 40 OHM/3000 W	High	35

[200V]

Inverter	Braking resistor	Duty Cycle	Minimum resistance value [Ω]
FRN3,7E1S-2A	RES PR 33 OHM/600 W	Standard	33
FRN5,5E1S-2A	RES PR 20 OHM/600 W	Standard	20
FRN7,5E1S-2A	RES PR 20 OHM/600 W	Standard	15
	RES PR 15 OHM/1000 W	High	15
FRN11E1S-2A	RES PR 10 OHM/1500 W	Standard	9
FRN15E1S-2A	RES PR 9 OHM/3000 W	High	9



Spain Office

Fuji Electric FA España

Ronda Can Fatjó 5, Edifici D, Local B
Parc Tecnològic del Vallès
08290 Cerdanyola (Barcelona)
Espanya
Tel.: +34 93 582 43 33 · Fax.: +34 93 582 43 44
mailto: droy@fujielectric.de

Head office

Fuji Electric FA Europe GmbH

Goethering 58
63067 Offenbach/Main
Germany
Tel.: +49 (0) 69 669029-0 · Fax.: +49 (0)69 669029-58
mailto: info_inverter@fujielectric.de
www.fujielectric.de