



## OPERATION MODES WITH G11 INVERTER AND OPC-G11S-PG/PG2/PGA/SY OPTION CARD

### 1. Operation modes.

The operation mode can be selected by function o01.

The first digit (units) of this function defines the speed control method (open or closed loop,...).

The second digit (tenths) of this function defines the speed command setting method (type of pulse train, synchronous operation,...):

The following table shows the different alternatives.

<b>o01 value</b>	<b>Mode</b>	<b>Option card needed</b>
00	Open loop (speed feedback inactive) Speed command by analog setpoint, preset speeds,...	None
01	Closed loop vector Speed command by analog setpoint, preset speeds,...	PG, PG2, PGA, SY
02	Closed loop V/f (with A/B phase feedback) Speed command by analog setpoint, preset speeds,...	PG, PG2, PGA, SY
03	Line-speed control (with A/B phase feedback) Speed command by analog setpoint, preset speeds,...	PG, PG2, PGA, SY
04	Closed loop V/f (with B phase feedback) Speed command by analog setpoint, preset speeds,...	PG, PG2, PGA, SY
05	Line-speed control (with B phase feedback) Speed command by analog setpoint, preset speeds,...	PG, PG2, PGA, SY
10	Open loop (speed feedback inactive) Speed command by pulse train (A/B phase pulse train)	PG, SY, PG2
11	Closed loop vector Speed command by pulse train (A/B phase pulse train)	PG, SY, PG2
12	Closed loop V/f (with A/B phase feedback) Speed command by pulse train (A/B phase pulse train)	PG, SY



Table with different alternatives (continued):

<b>o01 value</b>	<b>Mode</b>	<b>Option card needed</b>
13	Line-speed control (with A/B phase feedback) Speed command by pulse train (A/B phase pulse train)	PG, SY
14	Closed loop V/f (with B phase feedback) Speed command by pulse train (A/B phase pulse train)	PG, SY
15	Line-speed control (B phase feedback) Speed command by pulse train (A/B phase pulse train)	PG, SY
20	Open loop Speed command by pulse train (only phase B pulse train)	PG, SY, PG2
21	Closed loop vector Speed command by pulse train (only phase B pulse train)	PG,SY, PG2
22	Closed loop V/f Speed command by pulse train (only phase B pulse train)	PG,SY
23	Line-speed control (with A/B phase feedback) Speed command by pulse train (only phase B pulse train)	PG, SY
24	Closed loop V/f (with B phase feedback) Speed command by pulse train (only phase B pulse train)	PG, SY
25	Line-speed control (B phase feedback) Speed command by pulse train (only phase B pulse train)	PG, SY
31	Closed loop vector Master-Slave synchronous operation	SY, PG2



The following diagram shows the different alternatives in a graphical format.

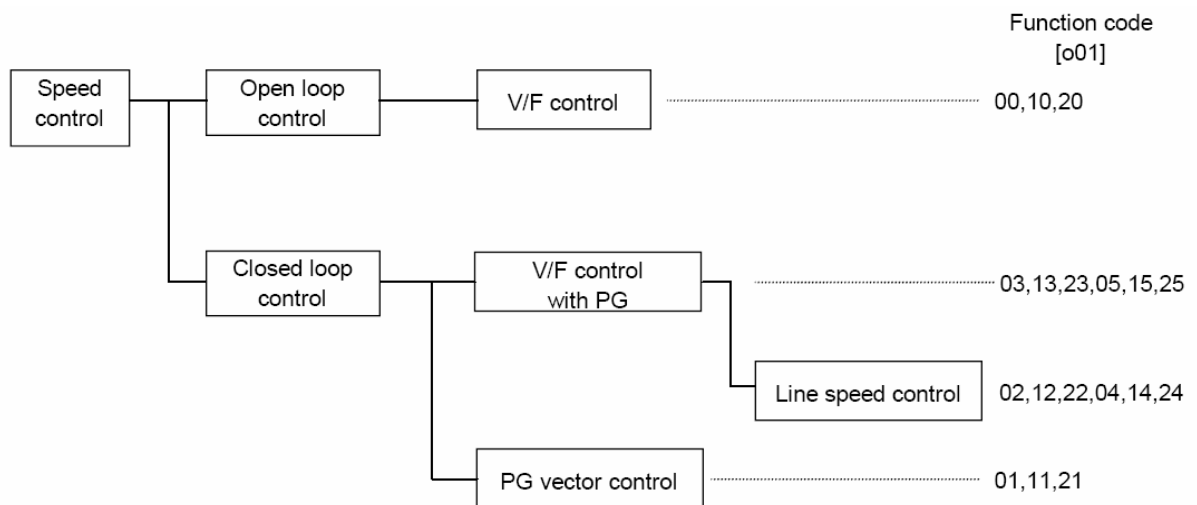

Figure 1. Different alternatives for speed control.

## 2. Closed loop operation.

### 2.1 Functions related to closed loop operation.

o02: Speed command filter time constant.

o03: Encoder Pulse count on the slave side. This function is used to set the encoder pulse count (pulses per revolution) on the slave side.

o04: P constant of speed controller on slave side.

o05: I constant of speed controller on slave side.

o06: Speed detection filter time constant on slave side.

o07: Pulse correction coefficient 1 on slave side.

o08: Pulse correction coefficient 2 on slave side.

$$Actual\_slave\_motor\_speed = \frac{o08}{o07} \times Slave\_side\_encoder\_shaft\_speed$$



## 2.2 Example of setup with closed loop operation.

A possible case is when the encoder (PG) is not directly coupled to the motor but connected through a gearbox. In that case function codes o07 and o08 can be used to setup the correct ratio between motor speed and encoder speed.

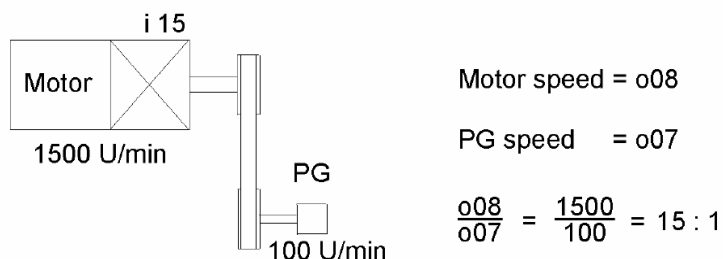

Figure. Example of setup with closed loop operation.

## 3. Speed command by pulse train.

### 3.1 Functions related to speed command by pulse train.

F01: Frequency setting 1. Set to 11 to use frequency setting by pulse train.

o10: Pulse setting filter time on speed command side.

o11: Pulse correction coefficient 1 on speed command side.

o12: Pulse correction coefficient 2 on speed command side.

$$\text{Frequency\_Command (Hz)} = \frac{o12}{o11} \times \text{Command\_side\_Encoder\_frequency (kp/s)}$$

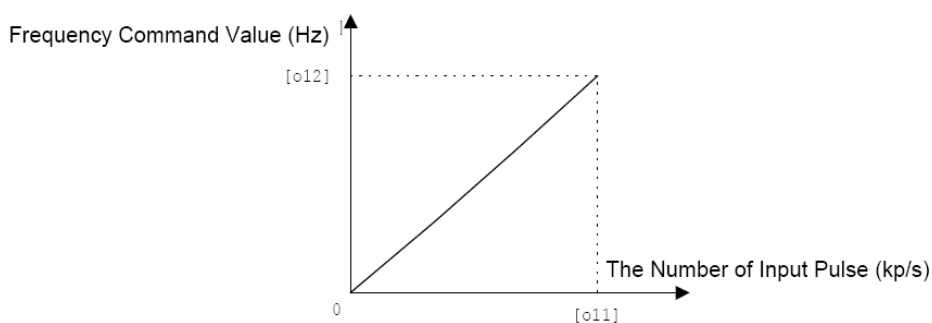

Figure 2. Relationship between pulse input frequency and frequency command.

o13: Main speed controller gain. Set to 1.0.



## 4. Synchronous operation.

### 4.1 Functions related to synchronous operation.

F01: Frequency setting 1. Set to 11 to use synchronous operation.

o02: Speed command filter time constant.

o03: Encoder Pulse count on the slave side. This function is used to set the encoder pulse count (pulses per revolution) on the slave side.

o04: P constant of speed controller on slave side.

o05: I constant of speed controller on slave side.

o06: Speed detection filter time constant on slave side.

o07: Pulse correction coefficient 1 on slave side.

o08: Pulse correction coefficient 2 on slave side.

$$Actual\_slave\_motor\_speed = \frac{o08}{o07} \times Slave\_side\_encoder\_shaft\_speed$$

o09: Encoder pulse count on command side. This function is used to set the encoder pulse count of the motor on the command (master) side.

o10: Pulse setting filter time constant on command (master) side.

o11: Pulse correction coefficient 1 on command (master) side.

o12: Pulse correction coefficient 2 on command (master) side.

$$Speed\_Command\_side = \frac{o12}{o11} \times Command\_side\_encoder\_shaft\_speed$$

o13: Main speed controller gain. This function is used to minimize the following error during motion. Set to 1.0 to minimize this error.

o14: APR (Position controller) P Gain. This function is used to minimize the steady state error of the position regulator.

o17: Synchronization detection completion angle. This function is used to set the value of the position (angle) difference between master and slave under which the inverter (slave) considers is in phase with the master. Programming function 29 to any of the digital outputs then they will be active (ON state) when this condition is met.



o18: Deviation limit violation width. This function is used to set the value (**multiplied by 10**) of the position (angle) difference between master and slave over which the inverter (slave) considers that is not synchronized with the master. In that case the inverter will trip with alarm Err5.

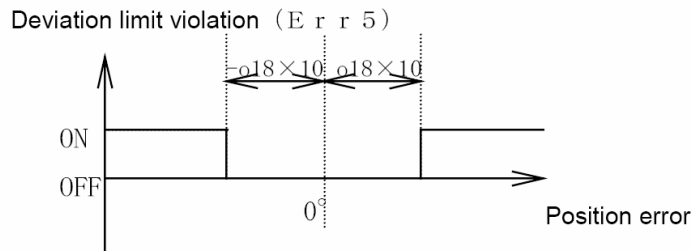

Figure 3. Deviation limit violation error.

#### 4.2 Synchronous operation setting example.

In the case of the system set up of the figure below.

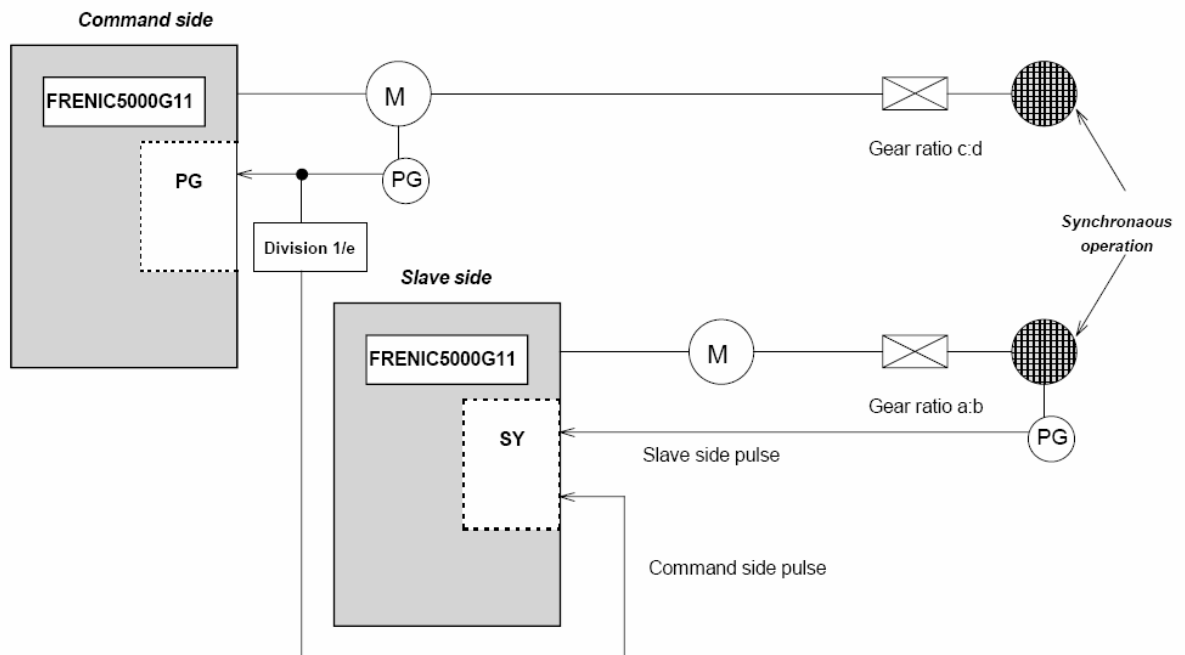

Figure 4. Example system setup.

The parameter setup will be:

o07=a

o08=b

o11=d

o12=c x e



### 4.3 List of function codes with different meaning.

The meaning of some function codes become different during synchronous operation. This function codes and their new meaning are listed in the table below.

Function number	Name	Setting	Meaning
F14	Auto restart	0	Inactive (Immediately tripping without restarting)
		1	Inactive (Tripping upon recovery without restarting)
		2	Inactive (Immediately tripping without restarting)
		3	Active (Restarting to original position)
		4	
5			
E16	Torque limiter 2 (driving)	20 to 200	The APR output is limited between 20 and 200% of the reference side speed (positive side).
		999	No limiter on negative side of APR output
E17	Torque limiter 2 (regenerating)	0	Active at 20%
		20 to 200	The APR output is limited between 20 and 200% of the reference side speed (negative side).
		999	No limiter on negative side of APR output

#### 4.4 Invalidated function list.

Some functions are invalidated during synchronous operation. This function codes are listed in the table below.

Function	Name	Remarks
F06	Maximum voltage 1	Under PG vector control
F07	Acceleration time 1	
F08	Deceleration time 1	
F09	Torque boost 1	Under PG vector control
F16	Frequency limiter lower	
F23	Starting Frequency: Frequency	
F24	Starting Frequency: Holding time	
F25	Stop frequency	Invalid with operation command Valid without operation command
F42	Torque vector control 1	Under PG vector control
E01-E09	X terminal function selection: Torque limit 2 / Torque limit 1	
E10	Acceleration time 2	
E11	Deceleration time 2	
E12	Acceleration time 3	
E13	Deceleration time 3	
E14	Acceleration time 4	
E15	Deceleration time 4	
C01-C03	Jump frequency 1 to 3	
C04	Hysteresis	
H07	Acc/Dec Pattern	
H10	Automatic energy-saving operation	
H14	Auto-restart: Freq fall ratio	
H15	Auto-restart: Holding DC ratio	
H19	Active drive	
A04	Maximum voltage 2	Under PG vector control
A05	Torque boost 2	Under PG vector control
A09	Torque vector control 2	Under PG vector control