

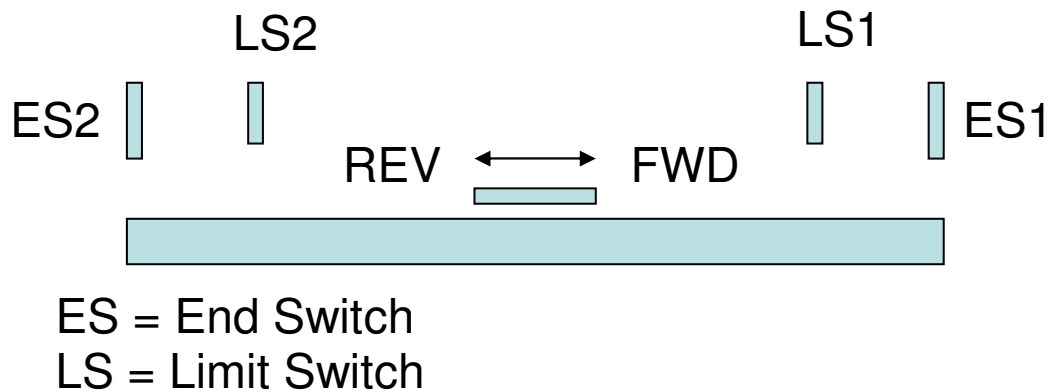

Application Note

Application: Traverse Operation with G11



Description: A traveller should move from one side of the machine to the other side then hit the limit switch, decelerate to 0Hz and start in the other direction. Hit the second limit switch and decelerate to 0Hz and restart in the first direction and so on.

Requirements: Only 1 Control Switch available (ON / OFF)
Traveller should start on every traveller position
Hitting the end switches should immediately stop the inverter
On change from FWD to REV or REV to FWD, HLD and FWD / REV signal might be detected in wrong order (FWD / REV before HLD) and therefore cause the inverter to stop.

Proposed Solution: Figure1 describes the external wiring.

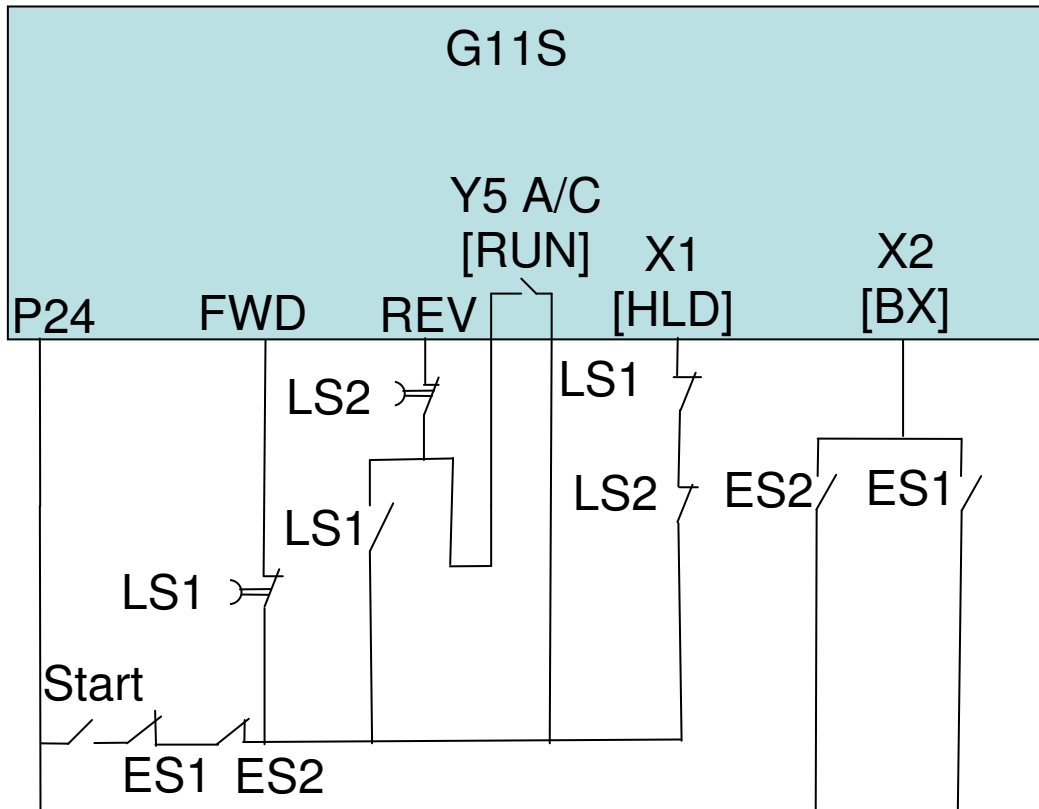

Figure 1. Control wiring

The following parameters have to be set:

Parameter Setting

F02	1	Operation command by FWD and REV Terminal
E01	6	3-wire operation
E02	7	Coast to stop command
E24	0	Inverter Running
E25	0	Inactive (Y5 Ry excites at “ON signal” mode)

The double usage of ES1 and ES2 is due to safety. The serial connection after the Start switch will cause the inverter to Stop but by using a deceleration ramp. The parallel connected normally open contacts will activate BX command which immediately cuts the output of the inverter but in case of a broken wire might not operate properly.

Important note:

The switches connected to FWD and REV must be break contacts with a delayed closing to avoid the problems caused by detection of HLD and FWD / REV signals in wrong order.

To understand the timing problem please see the following timing diagrams.



State 1: Start command is given (traveller position in the middle of the machine)

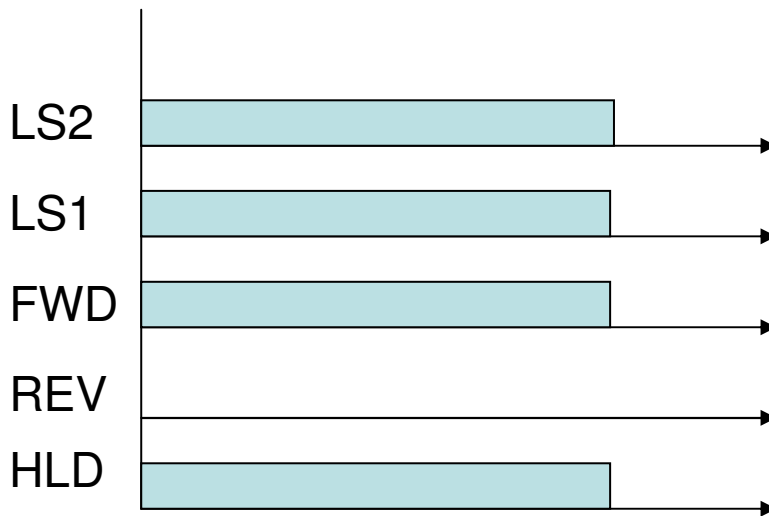

FWD is in ON condition because the limit switch 1 is still closed
 REV is in OFF condition because RUN signal is in off condition
 HLD is in ON condition because no limit switch has been hit

The Inverter is will run in forward direction

State 2: Before reaching the Limit Switch 1

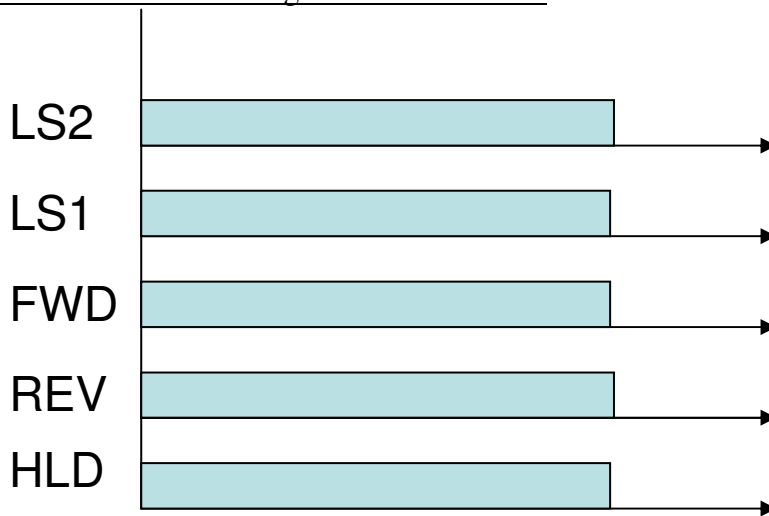

FWD is in ON condition because the limit switch 1 is still closed
 REV is in ON condition because the limit switch 2 is still closed and RUN signal is in on condition
 HLD is in ON condition because no limit switch has been hit



State 3: Hitting the Limit Switch 1

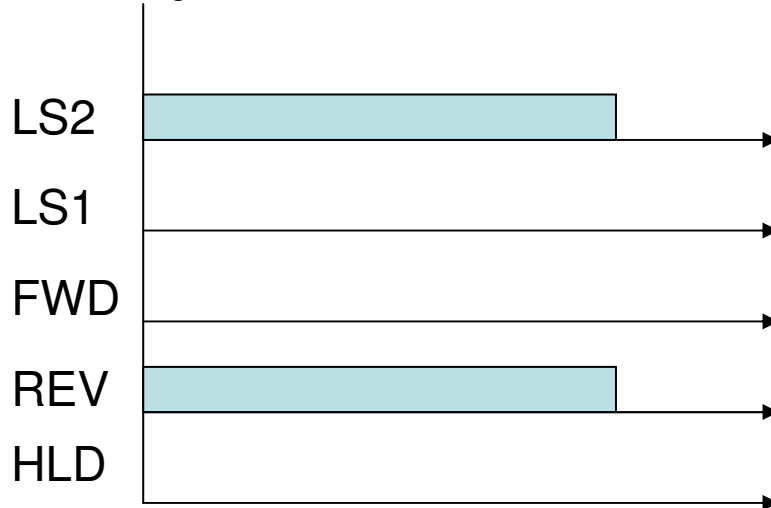

FWD is in OFF condition because the limit switch 1 is open
 REV is in ON condition because the limit switch 2 is still closed and the normally open contact of limit switch 1 is closed
 HLD is in OFF condition because limit switch 1 is open

The Inverter will decelerate to standstill and then start in reverse direction

State 4: After starting in reverse direction

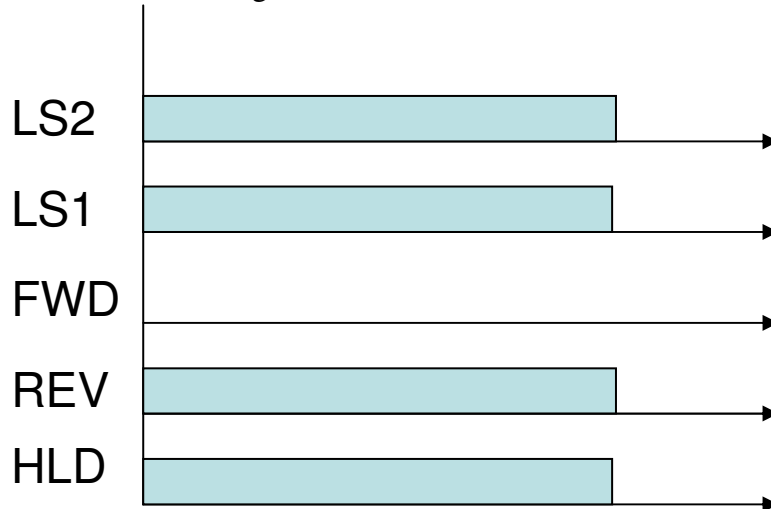

FWD is in OFF condition because of the delayed closing
 REV is in ON condition because limit switch 2 is closed and RUN signal is in on condition
 HLD is in ON condition because no limit switch has been hit



State 5: After closing the delayed brake contact of limit switch 1

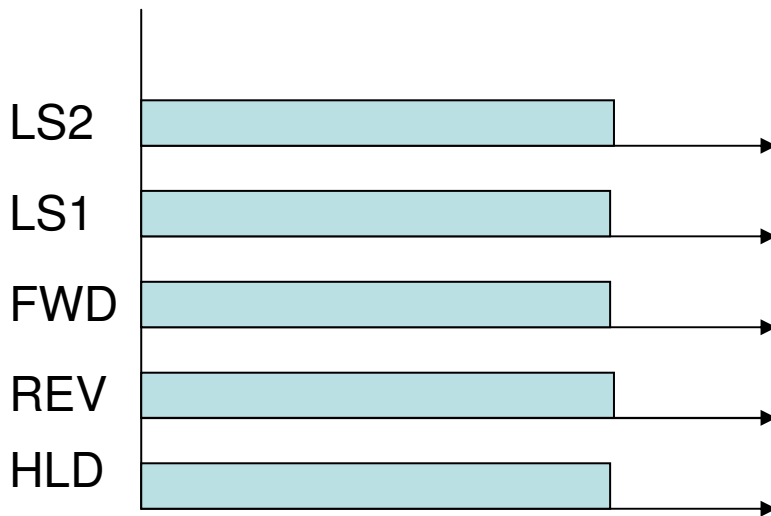

FWD is in ON condition because the limit switch 1 is closed
 REV is in ON condition because the limit switch 2 is closed and RUN signal is in on condition
 HLD is in ON condition because no limit switch has been hit

Due to this there will never be the problem of FWD and REV both in on condition before 3-wire operation started.

State 6: Hitting Limit Switch 2

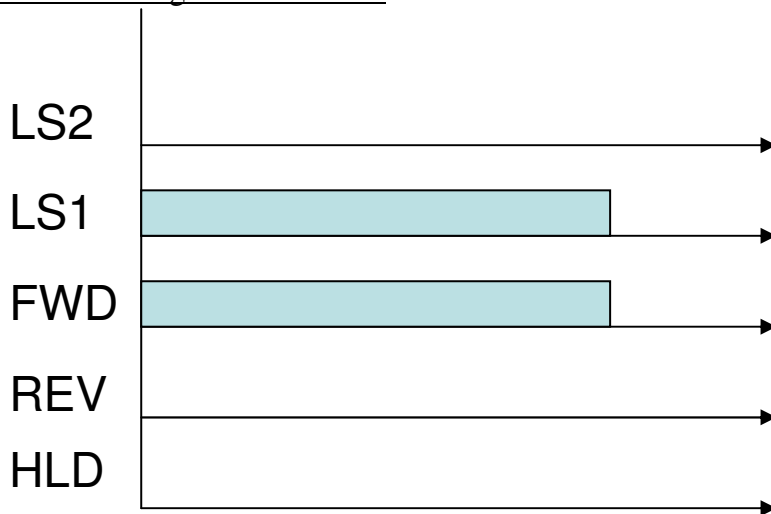

FWD is in ON condition because the limit switch 1 is still closed
 REV is in OFF condition because the limit switch 2 is hit
 HLD is in OFF condition because limit switch 2 has been hit

The Inverter will decelerate to standstill and start in forward direction.



State 7: After starting in forward direction

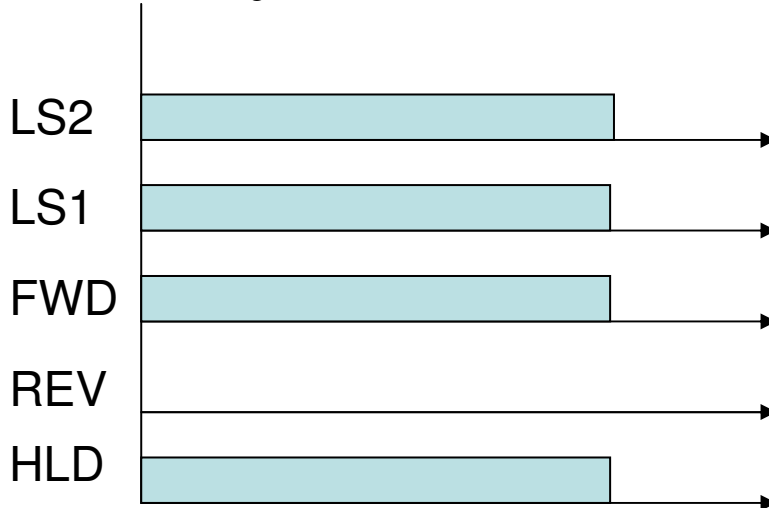

FWD is in ON condition because the limit switch 1 is still closed
 REV is in OFF condition because of the delayed closing
 HLD is in ON condition because no limit switch has been hit

State 8: After closing the delayed brake contact of limit switch 1

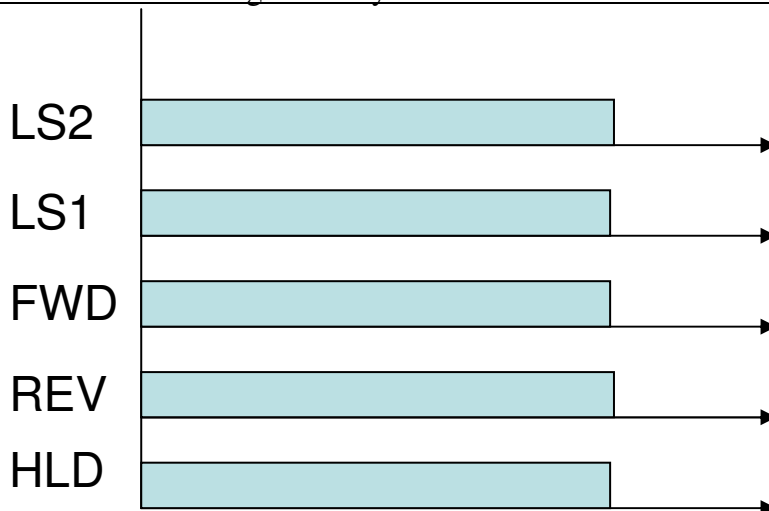

FWD is in ON condition because the limit switch 1 is closed
 REV is in ON condition because the limit switch 2 is closed and RUN signal is in condition
 HLD is in ON condition because no limit switch has been hit



CONTACT INFORMATION

Headquarter Europe

Electric FA Europe GmbH

Goethering 58
63067 Offenbach/Main
Germany
Tel.: +49 (0)69 669029 0
Fax: +49 (0)69 669029 58
info_inverter@fujielectric.de
www.fujielectric.de

Germany

Fuji Electric FA Europe GmbH
Sales area South
Drosselweg 3
72666 Neckartailfingen
Tel.: +49 (0)7127 9228 00
Fax: +49 (0)7127 9228 01
hgneiting@fujielectric.de

Switzerland

Fuji Electric FA Schweiz
ParkAltenrhein
9423 Altenrhein
Tel.: +41 71 85829 49
Fax.: +41 71 85829 40
info@fujielectric.ch
www.fujielectric.ch

Headquarter Japan:

Fuji Electric FA Components & Systems Co. Ltd

Mitsui Sumitomo Bank Ningyo-cho Bldg. 5-7
Nihonbashi Odemma-cho
Chuo-ku
Tokio 103-0011
Japan
Tel.: +81 3 5847 8011
Fax: +81 3 5847 8172
www.fujielectric.co.jp/fcs

Fuji Electric FA Europe GmbH

Sales area North
Friedrich-Ebert-Str. 19
35325 Mücke
Tel.: +49 (0)6400 9518 14
Fax: +49 (0)6400 9518 22
mrost@fujielectric.de

Spain

Fuji Electric FA España
Ronda Can Fatjó 5, Edifici D, Local B
Parc Tecnològic del Vallès
08290 Cerdanyola (Barcelona)
Tel.: +34 93 5824333/5
Fax: +34 93 5824344
droy@fujielectric.de